

GL-1800F-10TB



High Security Stainless Steel Magnet

- Operating voltage 12 or 24Vdc
- Stainless Steel
- Holding force up to 1800lbs (818kg)
- Face mount on sliding doors
- Weather resistant - IP67
- Vandal resistant
- Suitable for prison or high security gate



WEATHER
RESISTANT
– IP 67 –



VANDAL
RESISTANT



STAINLESS
STEEL

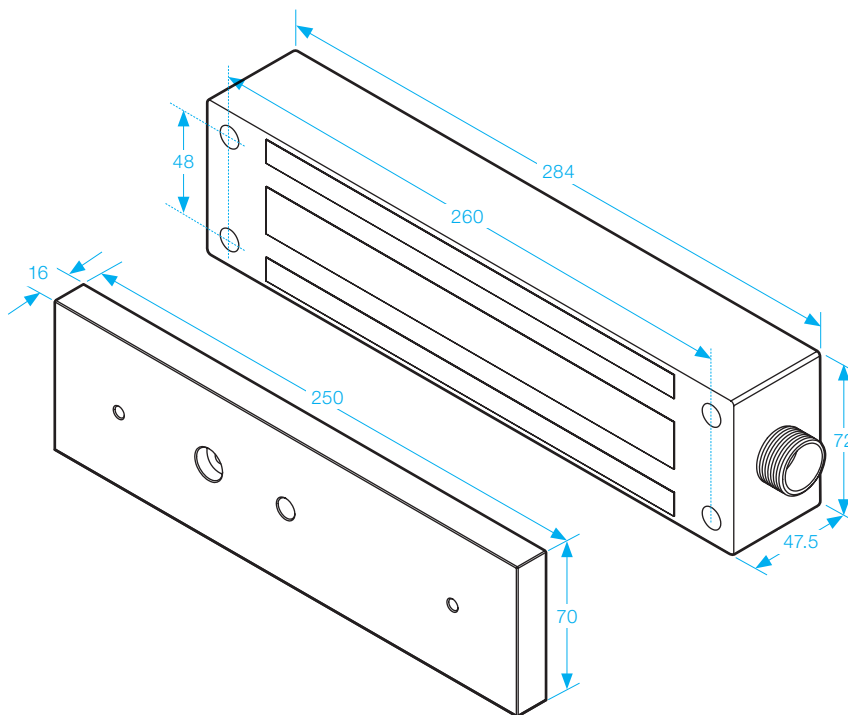

WATERPROOF PROPERTIES

This series of waterproof magnetic locks are sealed with an epoxy potting compound (E87252 (S), UL94V-0) and is protected by this compound. They are proved to withstand a water resistance as established in test procedures of IP 65.



SPECIFICATION

- Voltage tolerance: $\pm 15\%$.
- Current draw: 500mA at 12Vdc, 250mA at 24Vdc (at temperature 20°C).
- Operating temperature: -10~55°C (14 to 131°F).
- Lock's surface temperature: Current temperature $\pm 20\%$ (when power is on).
- Humidity: 0~95% non-condensing.
- Special Zinc finish for magnet.
- Weight: 8.0kg (approx).