

# GEM800LD

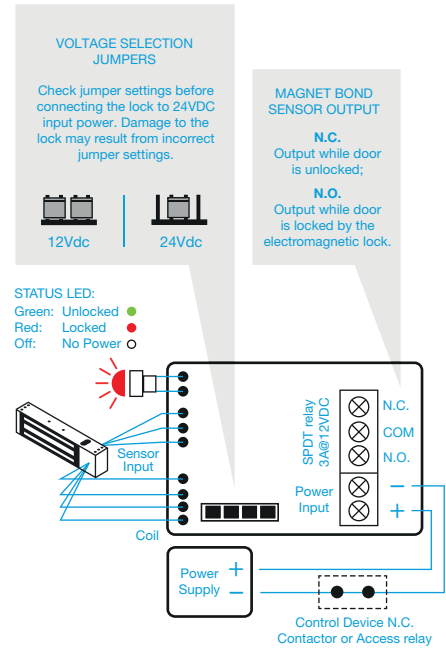

## Midi Magnet

- Operating voltage 12~24Vdc
- Aluminium
- Fail-Safe (*Power to Lock*)
- Holding force up to 800lbs (363g)
- Surface mount
- Status LED ● Red ● Green

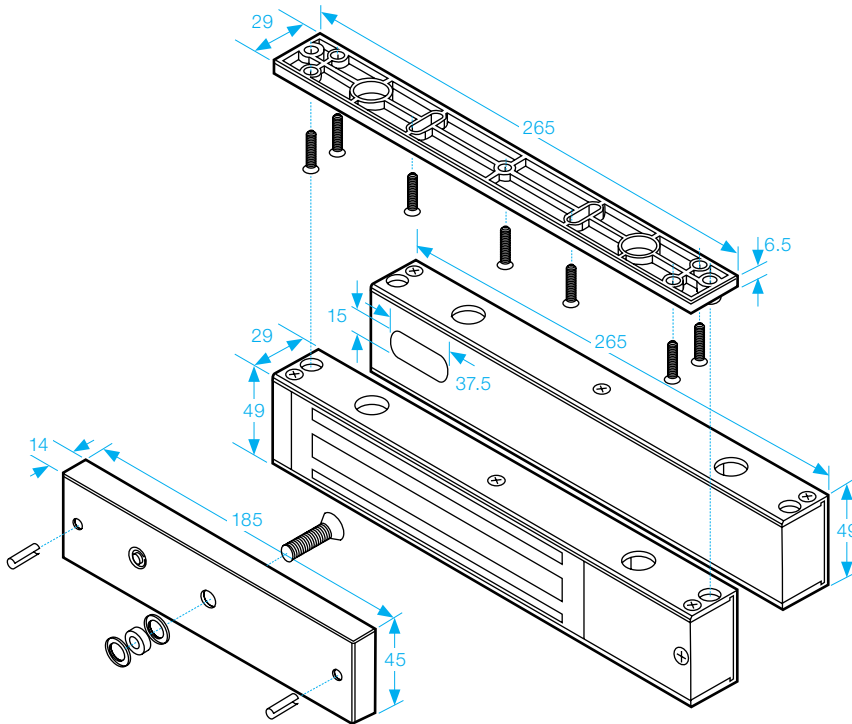
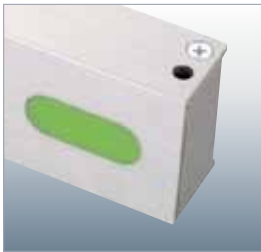

**SPECIFICATION**

- Voltage tolerance: ±15%.
- Current draw: 500mA at 12Vdc, 250mA at 24Vdc (at temperature 20°C).
- Operating temperature: -10~55°C (14 to 131°F).
- Lock's surface temperature: Current temperature ±20% (when power is on).

- Magnetic bond sensor monitor output remotely monitors the door lock or unlock status. (N.C. Output-Door opened; N.O. Output-door closed) (SPDT rated 3A at 12Vdc).
- Humidity: 0~95% non-condensing.
- Special Zinc finish for magnet and armature plate.
- Weight: 5.0kg (approx).